

PRODUCT NUMBER

45622801

CATALOG NUMBER

V-5622 FR
V-5622-80 GR

CATCH BASIN
ASSEMBLY

LOAD RATING

HEAVY DUTY

COATING

UNDIPPED

ESTIMATED WEIGHT

GRATE: 108 LBS 49kg
FRAME: 120 LBS 54kg
UNIT: 228 LBS 103kg

MATERIAL SPECIFICATION

GRATE - GRAY IRON
ASTM A48 CL35B
FRAME - GRAY IRON
ASTM A48 CL35B

OPEN AREA

156sq.in. 1006sq.cm.

✓ DESIGNATES MACHINED
SURFACE

DRAWN
DEW

DATE
12/09/03

LAST REVISED
DEW

DATE
07/12/06

REFERENCE INFORMATION

45622010
45622830

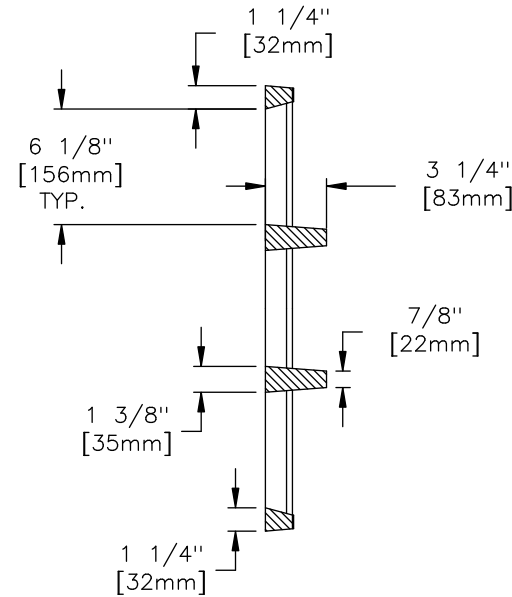
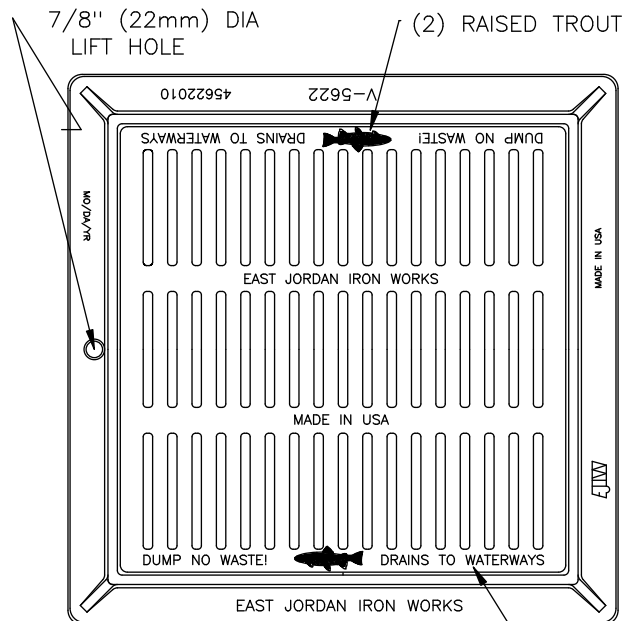

GRATE SECTION

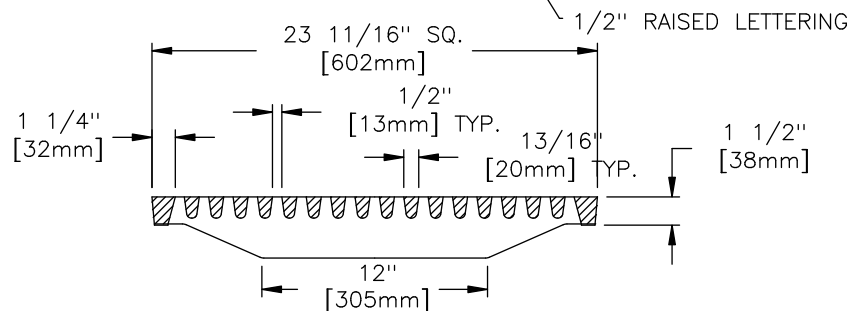

GRATE SECTION

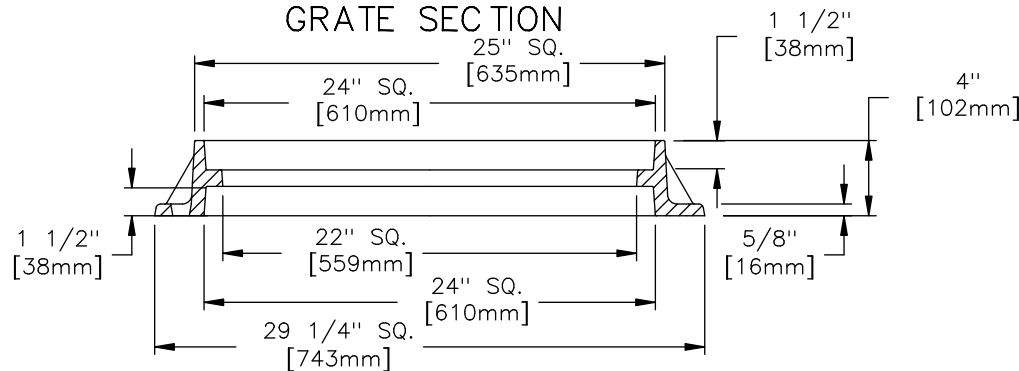

FRAME SECTION

NOTE:
FRAME IS REVERSIBLE
BOTTOM FLANGE V-5622
TOP FLANGE V-5822

GRATE DESIGNED TO BE IN ACCORDANCE
WITH ADA REQUIREMENTS (SECTION 4.5.4)